

Professional Door Design Specifications

External Assembled View

For Illustration Purposes Only - Not Drawn to Scale

All Dimensions Are Shown In Inches and Millimeters In Brackets

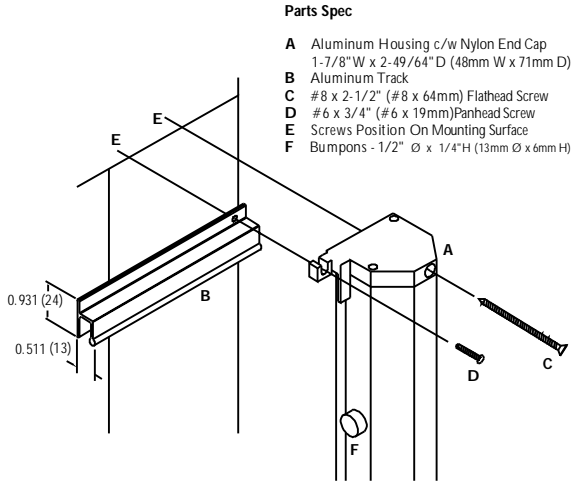

Parts Spec

- A Aluminum Housing c/w Nylon End Cap
1-7/8" W x 2-49/64" D (48mm W x 71mm D)
- B Aluminum Track
- C #8 x 2-1/2" (#8 x 64mm) Flathead Screw
- D #6 x 3/4" (#6 x 19mm) Panhead Screw
- E Screws Position On Mounting Surface
- F Bumpons - 1/2" Ø x 1/4" H (13mm Ø x 6mm H)

**DETAIL OF TRACK POSITION
IN RELATION
TO THE HOUSING AND HOUSING END CAP
(HEAD VIEW)**

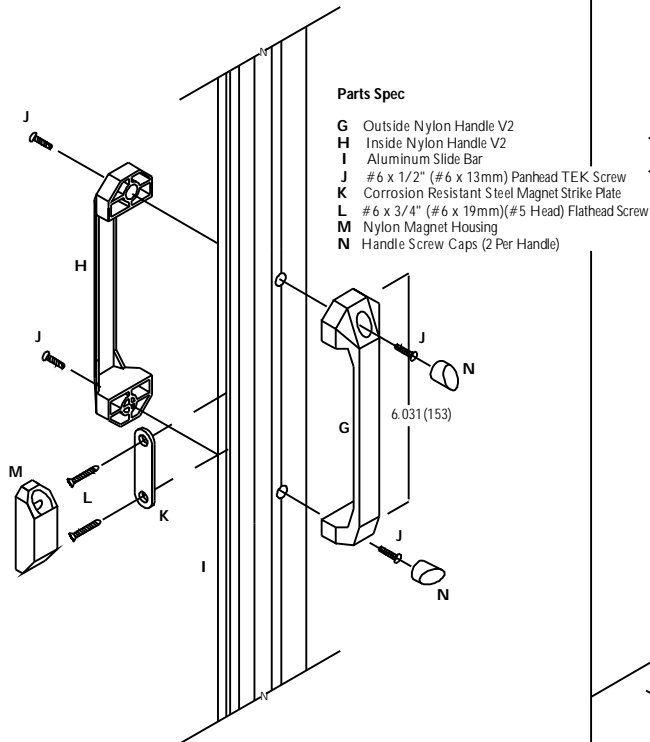

Parts Spec

- G Outside Nylon Handle V2
- H Inside Nylon Handle V2
- I Aluminum Slide Bar
- J #6 x 1/2" (#6 x 13mm) Panhead TEK Screw
- K Corrosion Resistant Steel Magnet Strike Plate
- L #6 x 3/4" (#6 x 19mm) (#5 Head) Flathead Screw
- M Nylon Magnet Housing
- N Handle Screw Caps (2 Per Handle)

**DETAIL OF HANDLE AND
STRIKE PLATE POSITION
IN RELATION
TO THE SLIDE BAR**

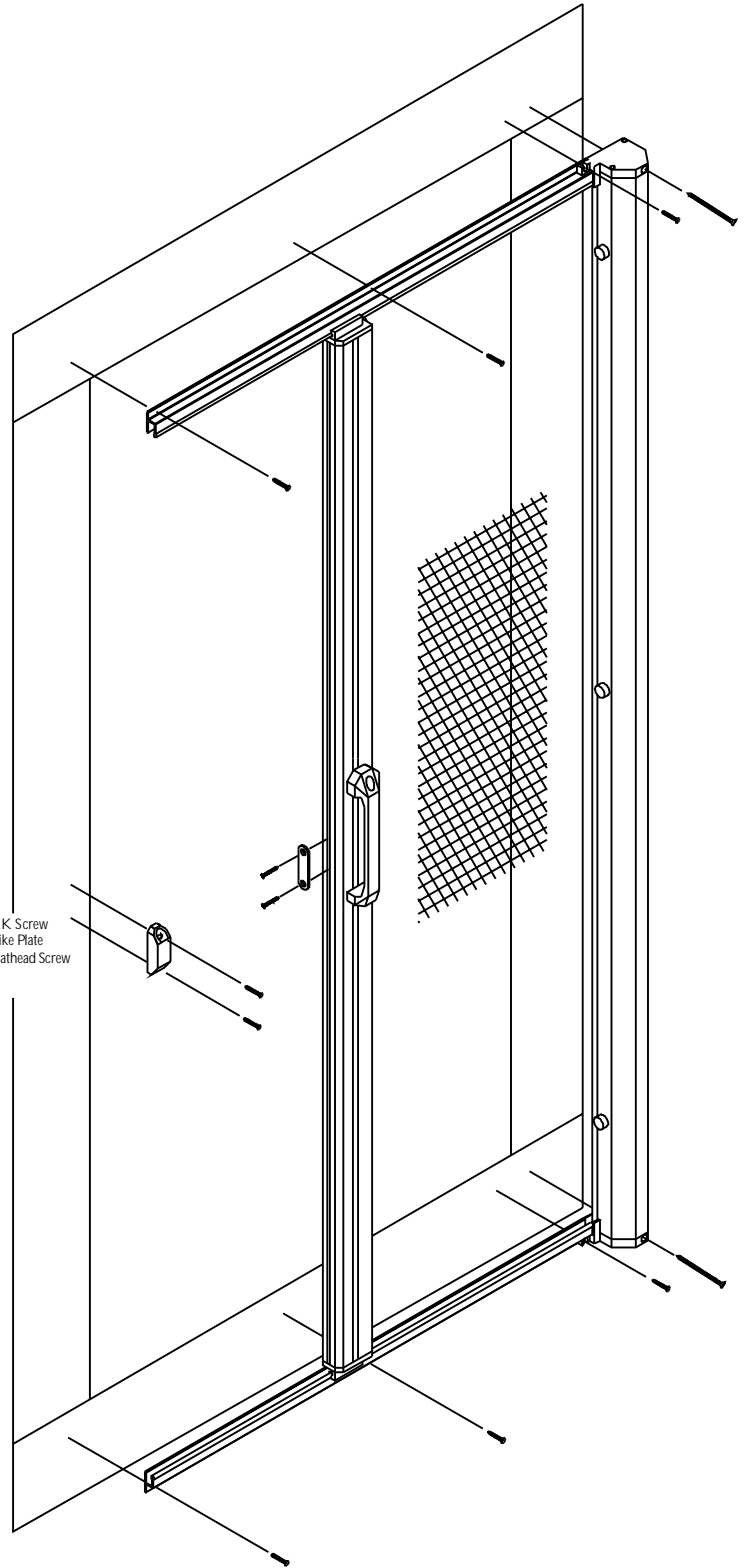

Creator: NDR	Date: 01/24/12	Revision: Rev:
Drawing Title: PSPROPRODDDESIGNSPEC01		
© 2012 Phantom Mfg. Intl Ltd.		Scale: NTS