

# EXECUTIVE DESIGN SPECIFICATIONS - MANUAL SYSTEM WITH STANDARD SIDE TRACK (V2A) (External Assembled View)

FOR ILLUSTRATION PURPOSES - NOT DRAWN TO SCALE

## Parts Spec

- A Housing Assembly:  
(5-1/2"W x 5-1/2"H)
- B #8 x 1" Corrosion Resistant Fastener (Color Matched)  
3 Fasteners per End Cap
- C PVC Coated Fiberglass Mesh  
or other - see Mesh Specifications
- D Standard Side Track (V2A) c/w Cover (1-3/4" W x 1-17/32" D)
- E #8 or #10 Corrosion Resistant Fastener  
Type and length of screws may  
vary depending on type of mounting surface
- F Slide Bar c/w Probe Assembly
- G Bottom Seal - 4" Shown (Other Options Available)

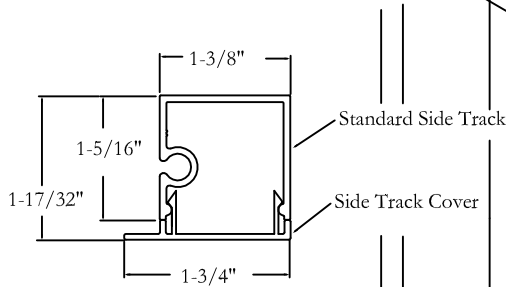

CROSS SECTIONAL VIEW  
OF THE  
STANDARD SIDE TRACK (V2A)

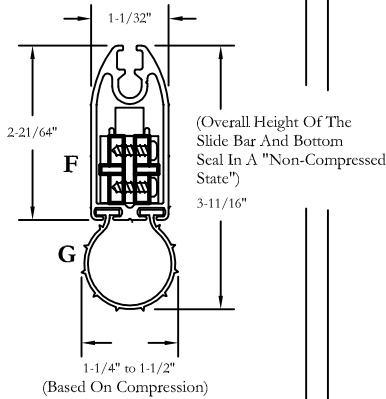

CROSS SECTIONAL VIEW  
OF THE SLIDE BAR AND  
4" BOTTOM SEAL

Scale: 1 : 1

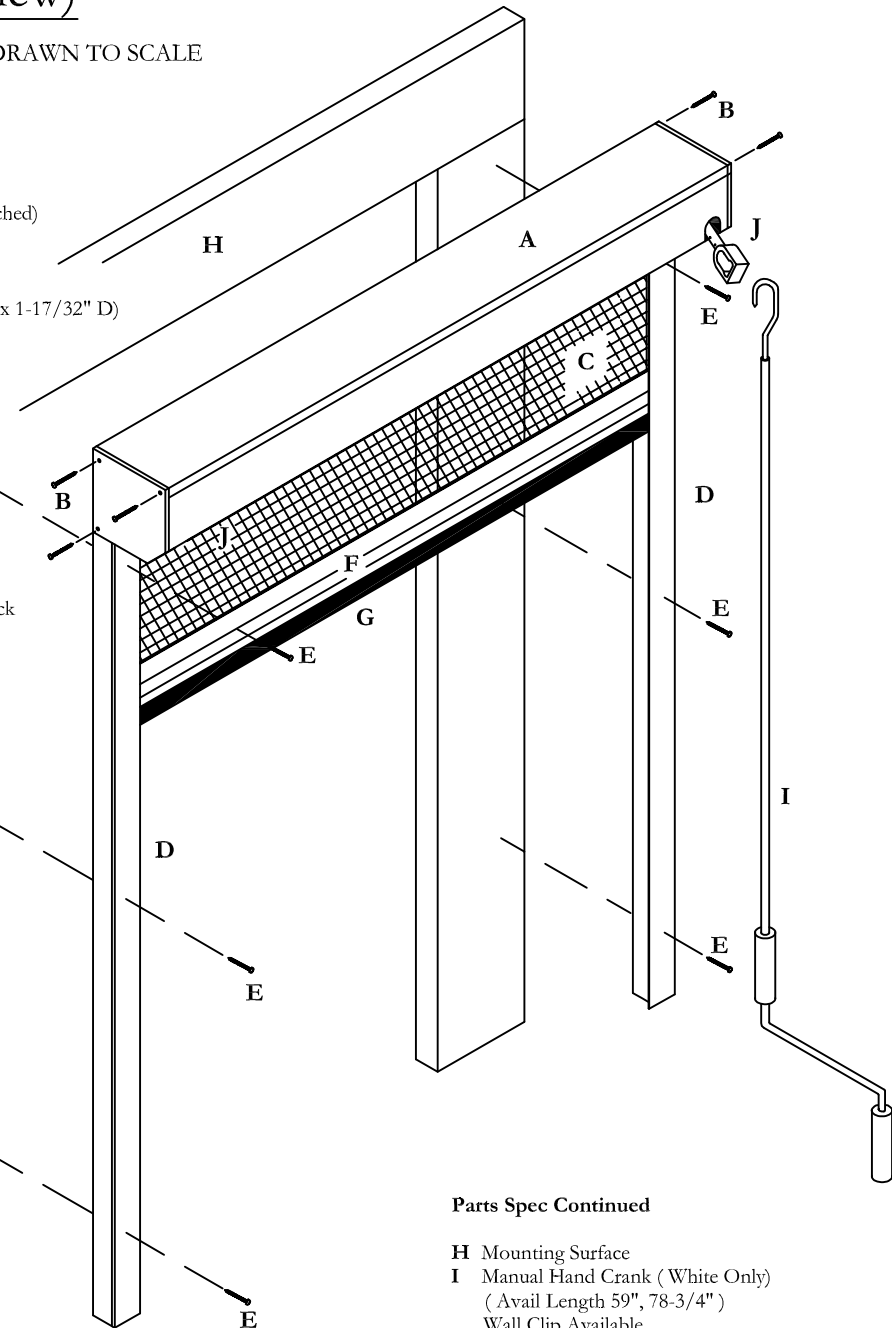

## Parts Spec Continued

- H Mounting Surface
- I Manual Hand Crank ( White Only)  
( Avail Length 59", 78-3/4")  
Wall Clip Available
- J Eye and Shaft for 11/1 Manual Gear  
Right Hand Mount Shown (Standard)

All components are color matched except Mesh, Bottom Seal, and Manual Hand Crank.

Rev: 01	Modify statement part list Item J Replace Slide Bar Assembly with new version
---------	--

Creator: NDR	Date: 07/17/2013	Revision: Rev: 01
-----------------	---------------------	----------------------

Drawing Title: <b>PSEXECPRODDESIGNSPEC08(A)</b>
--

© 2010 Phantom Mfg. Intl Ltd.	Scale: As Shown
-------------------------------	--------------------