

# MANUAL WALL SCREEN

(External Assembled View)

For Illustration Purposes Only - Not Drawn to Scale  
 All Dimensions Are Shown In Inches and Millimeters In Brackets

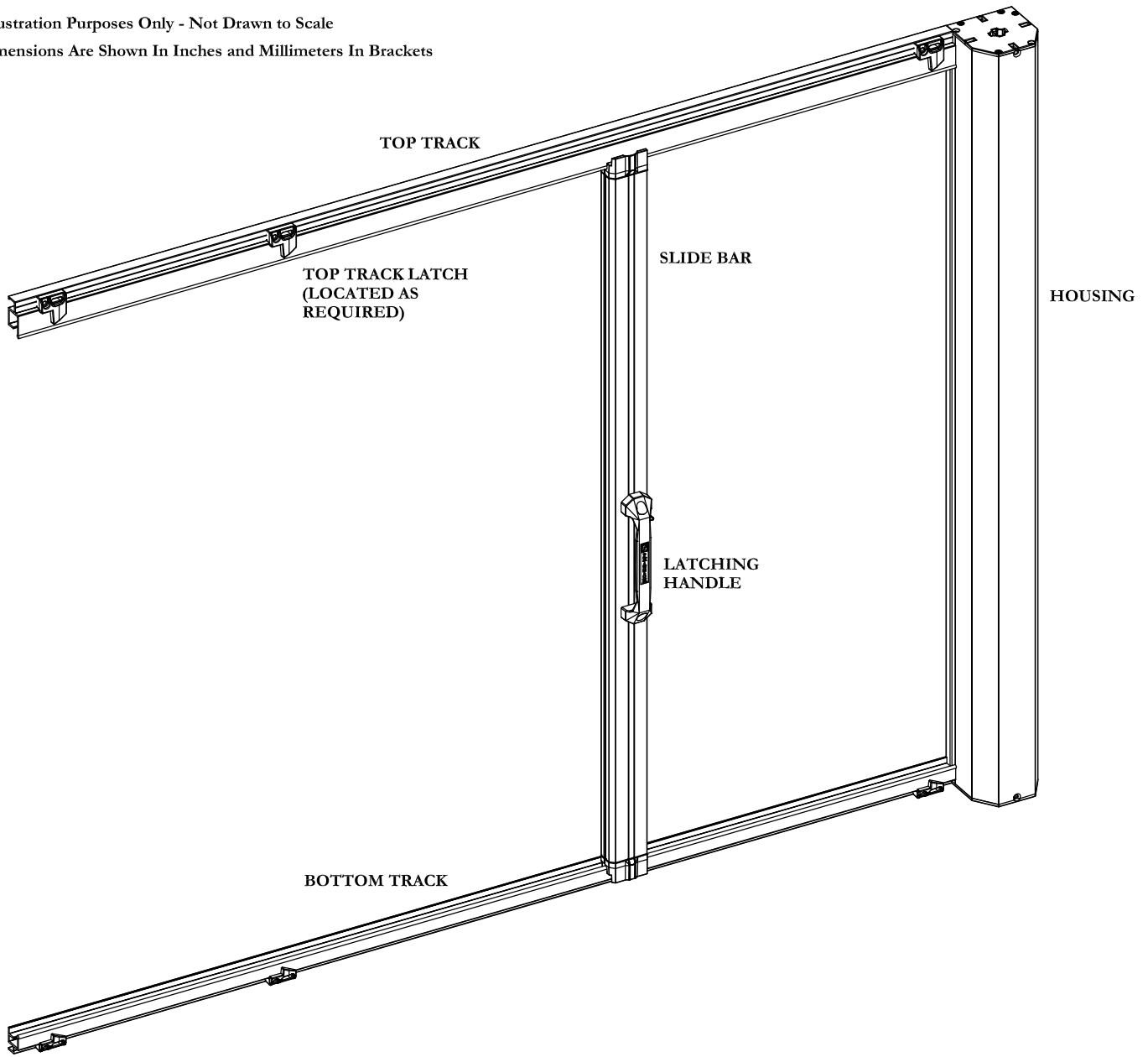

**BOTTOM TRACK LATCH (LOCATED AS REQUIRED)**

**Parts Spec**

- A Outside Nylon Handle
- B Inside Nylon Handle
- C Aluminum Slide Bar
- D #6 x 1/2" (#6 x 13mm) Panhead TEK Screw
- E Nickel Plated Zinc Lever Components
- F #6/32 x 1-5/8" S.S. Bolt
- G #6/32 Locknut S.S.
- H Handle Screw Caps (2 Per Handle)

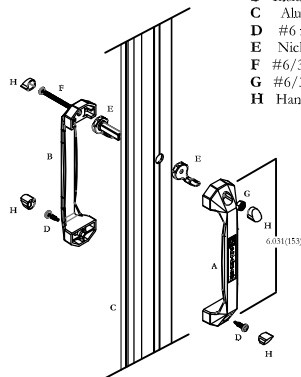

**DETAIL OF THE LATCH AND RELEASE HANDLE IN RELATION TO THE SLIDE BAR**

**NOTE(S);**

1. FOR INDIVIDUAL COMPONENT OVERALL SIZE SEE DRAWINGS - PSMANUALWALLSCREEN-02

Rev 1	Revision of part and title descriptions	N.D.R.	01/22/2018
Rev #	Description of Revision	Appr. by	Rev Date
Creator:	Date:	Revision:	
NDR	02/16/17	Rev: 01	
Drawing Title:			
PSRETRACTABLEWALLSCREENWLMHA15-01			
© 2017 Phantom Mfg. Intl Ltd.			Scale:
			NTS