

Phantom Door Design Specifications

(External Assembled View)

For Illustration Purposes Only - Not Drawn to Scale

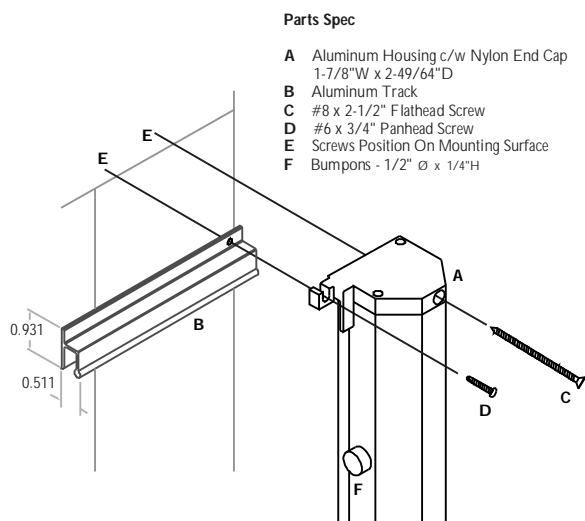

**DETAIL OF TRACK POSITION
IN RELATION
TO THE HOUSING AND HOUSING END CAP
(HEAD VIEW)**

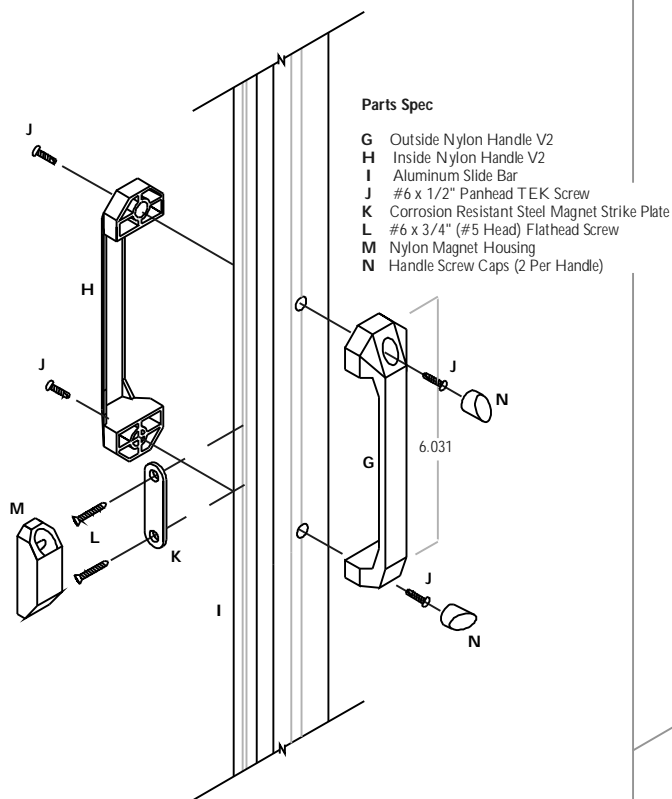

**DETAIL OF HANDLE AND
STRIKE PLATE POSITION
IN RELATION
TO THE SLIDE BAR**

